

Technical information Porter Euro 6 - Tipper



ENGINE	MultiTech	EcoPower	GreenPower
Engine	4-stroke, in-line 4-cylinder, 1,299 cc, dual overhead cam, electronic fuel injection, Euro		
Fuel	Petrol	petrol + LPG	petrol + CNG
Power*	61 kW @ 6.000 rpm	60 kW @ 6.000 rpm	54 kW @ 6.000 rpm
Torque*	112 Nm @ 4.300 rpm	108 Nm @ 4.300 rpm	97 Nm @ 4.300 rpm
Max Speed*	130 km/h		
Consumption (on combined cycle according to NEDC)*	6.1 l/100 km	8.4 l/100 km	4,2 kg/100 km
CO2 emission*	140 g/km	136 g/km	113 g/km
Total tank capacity*	35 (5) l Petrol	35 (5) l Petrol; 24 (6) l lpg	35 (5) l Petrol; 55 l cng

*referred to the Porter Deck version

RANGE	PORTER		MAXXI (short deck)			MAXXI (long deck)		
	MultiTech	Ecopower	MultiTech**	EcoPower	GreenPower	MultiTech**	EcoPower	GreenPower
Length x Width x Height	3.565x1.460x1.835 mm		3.830x1.560x1.815 mm			4.360x1.560x1.815 mm		
Wheelbase	1.830 mm		2.180 mm			2.180 mm		
Max. load bed space	1.405x1.940 mm		1.505x2.345 mm			1.505x2.775 mm		
Side height	400 mm		350 mm			350 mm		
Gross Vehicle Weight	1.700kg*		2.200kg			2.200kg		
Payload	790 kg	740 kg	1.060 kg	1.000 kg	940 kg	1.040 kg	990 kg	935 kg

* available also in 1.5 GTW version (200kg less payload)

** available also in HS version

Porter - Tipper

N1 Homologation Class

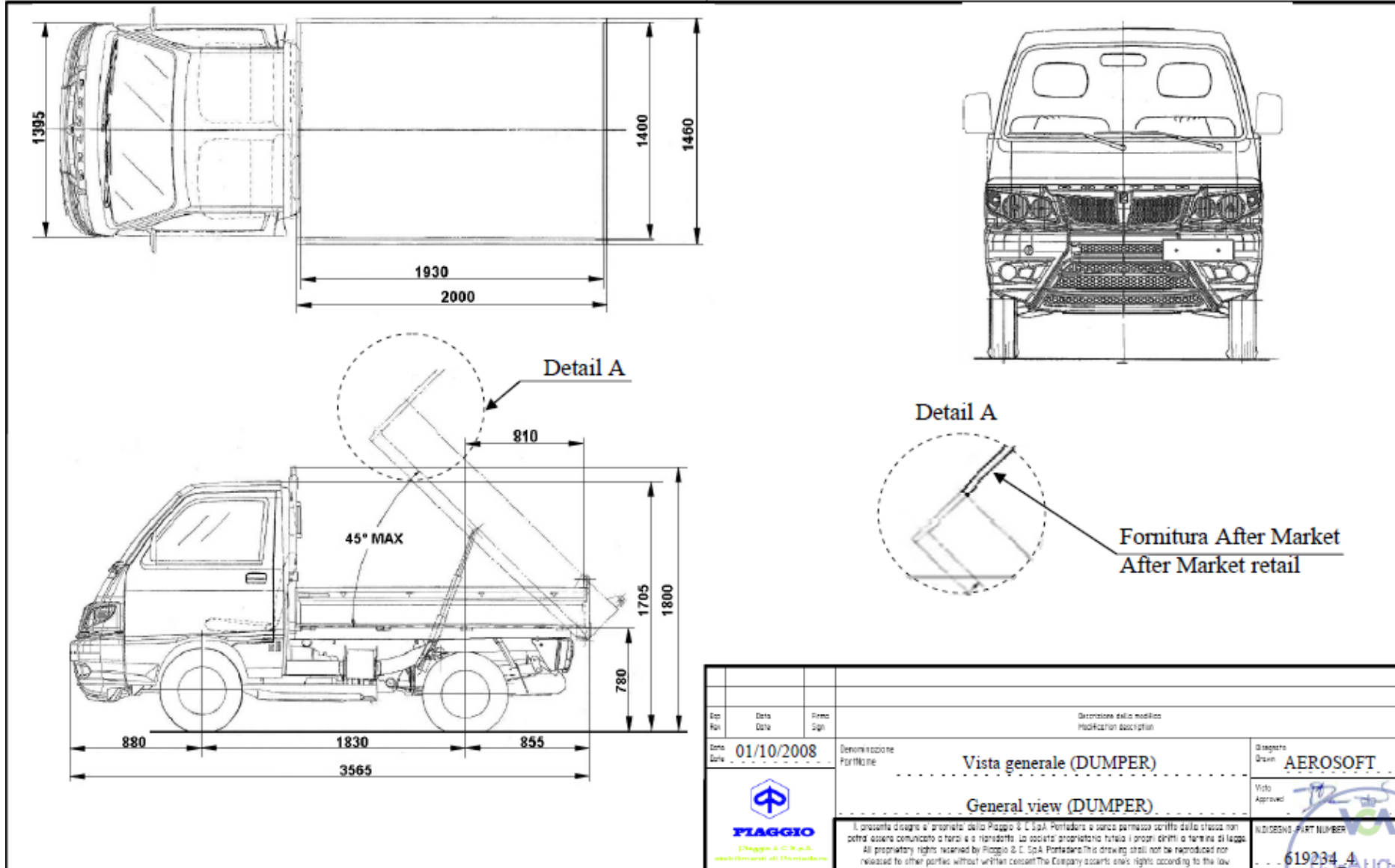

Rev	Date	Descr	Modificazioni
01	01/10/2008	Vista generale (DUMPER)	
<p>Il presente disegno è proprietà della Piaggio & C. S.p.A. e senza permesso scritto dello stesso non potrà essere comunicato a terzi e/o riprodotto. La società proprietaria tutela i propri diritti e termini di legge. All proprietary rights reserved by Piaggio & C. S.p.A. Portofino. This drawing shall not be reproduced nor released to other parties without written consent. The Company asserts one's rights according to the law.</p>			
<p>PIAGGIO Piaggio & C. S.p.A. www.piaggio.com</p>			N. DESIGN PART NUMBER 619234_4

Porter Maxxi – Tipper Short/Long deck

N1 Homologation Class

