

Technische informatie Porter Chassis

| MOTOR | MultiTech | EcoPower | GreenPower |
|------------------------------------|--|--|--|
| Motor | 4 cylinders, 1.299 cc Multipoint indirect injection - Euro 6 | 4 cylinders, 1.299 cc Multipoint indirect injection - Euro 6 | 4 cylinders, 1.299 cc Multipoint indirect injection - Euro 6 |
| Brandstof | benzine | benzine + LPG | benzine + CNG |
| Max Vermogenl* | 61 kW @ 6.000 rpm | 60 kW @ 6.000 rpm | 54 kW @ 6.000 rpm |
| Max Koppel* | 112 Nm @ 4.300 rpm | 108 Nm @ 4.300 rpm | 97 Nm @ 4.300 rpm |
| Topsnelheid* | 130 km/h | | |
| Brandstof verbruik (combi)* | 6,5l x 100km | 8,6l x 100km | 7,0nm ³ x 100km |
| CO2 emission* | 150 | 139 | 125 |
| Totaal tank inhoud* | 40l | 40l benzine+ 30l lpg | 40l benzine + 55kg methaan |

**van toepassing voor Porter Deck versie*

| RANGE | PORTER | | | MAXXI** | | |
|----------------------------------|----------------------|-----------------|-------------------|----------------------|-----------------|-------------------|
| | MultiTech | EcoPower | GreenPower | MultiTech | EcoPower | GreenPower |
| Lengte x Breedte x Hoogte | 3.555x1.395x1.705 mm | | | 3.775x1.450x1.730 mm | | |
| Wielbasis | 1.830 mm | | | 2.180 mm | | |
| Max Laad Capaciteit | 850 kg* | 785 kg* | 720 kg* | 1.120 kg | 1.070 kg | 1.010 kg |

**ook beschikbaar in 1.5 GTW versie (200kg minder laadvermogen)*

***ook beschikbaar in HS versie (exclusief GreenPower)*

N1 Homologation Class

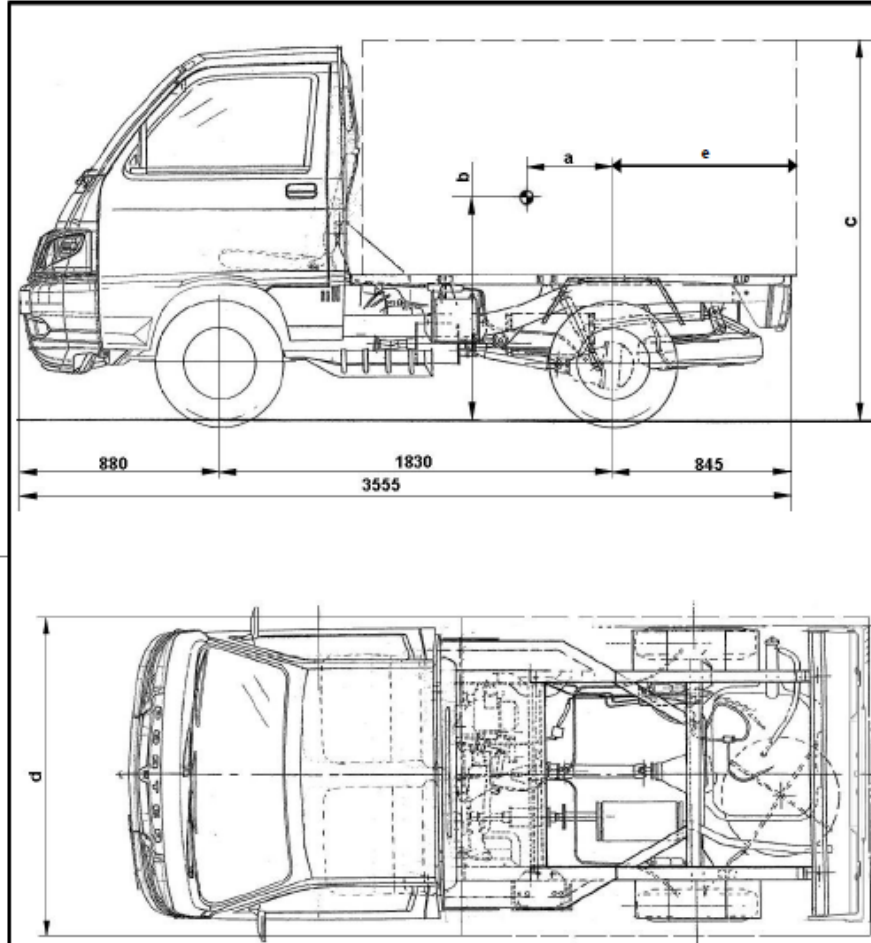

| | MIN | MAX |
|---|------|------|
| a | 150 | 331 |
| b | 600 | 750 |
| d | | 1500 |
| e | 845 | 1065 |
| Massa max ant. Front max mass | 715 | |
| Massa max post. Rear max mass | 1100 | |
| Massa minima imposta Min. running order mass | 850 | |
| % min. massa OdM su asse posteriore rear axle running order mass min % | 42% | |

Units in mm

| | | | | | |
|---|-------------------------------|--------------|---|--|--|
| 2 | 02/05/2016 | pd | foglio 2 per versioni CNG - sheet 2 for CNG versions | | |
| 1 | 16/11/2015 | pd | Inserito foglio 1 per varianti/versioni GPL - sheet 1 for LPG variants/versions | | |
| Exp. Rev. | Descr. | Finis. Sign. | Descrizione della modifica Modification description | | R C O D I F I C A T O R I O |
| 20/03/2015 | Indicazioni di carrozzabilità | | Disegnato Drawn: AEROSOFT | | |
| | | | Verificato Approved: [Signature] | | |
| Indication of dimensions for bodywork installation | | | NUMERO PART NUMBER 619637_1 | | |
| <small>Il presente disegno è proprietà della Piaggio & C SpA. Perfezionata e senza permesso scritto della stessa non potrà essere comunicato a terzi e o riprodotto. La società proprietaria tutela i propri diritti a termini di legge. All proprietary rights reserved by Piaggio & C SpA. Perfezionata. This drawing shall not be reproduced nor released to other parties without written consent. The Company asserts one's rights according to the law.</small> | | | | | |

Porter Chassis - Ecopower (GPL)

N1 Homologation Class

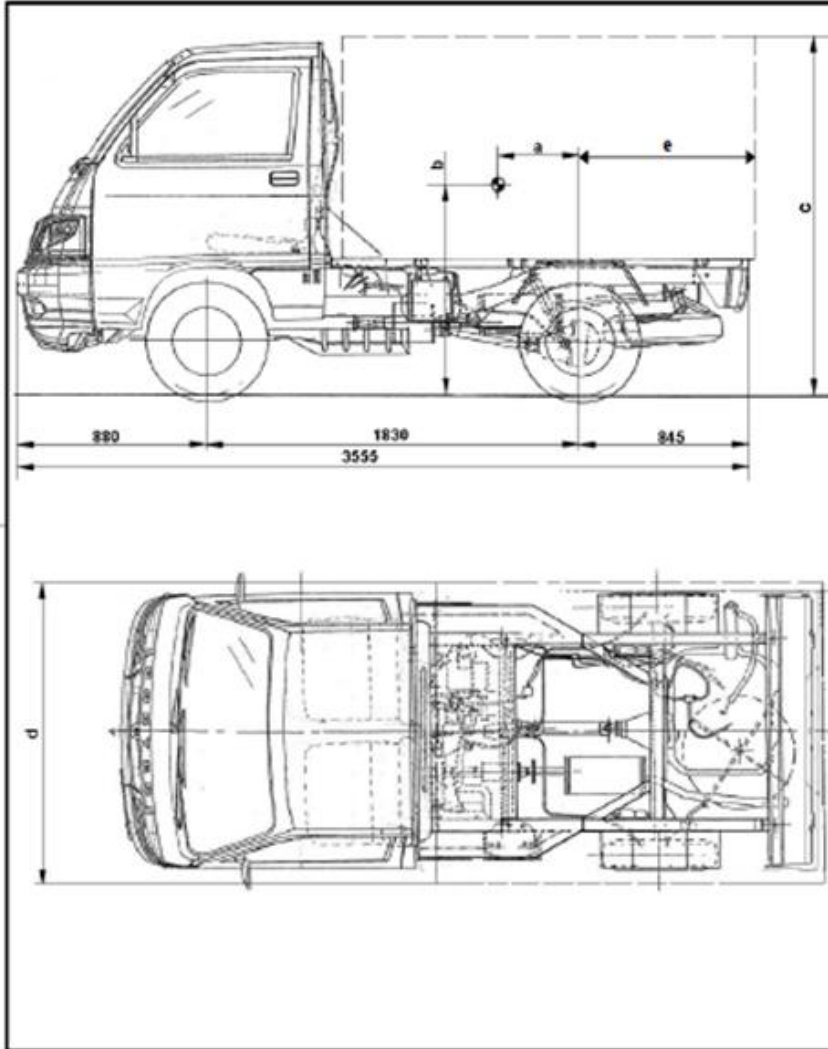

| VAR/VER: CG? / ??F (bi-fuel LPG) | | |
|---|------|------|
| | MIN | MAX |
| a | 125 | 268 |
| b | 600 | 750 |
| d | | 1500 |
| e | 845 | 1065 |
| Massa max ant. Front max mass | 715 | |
| Massa max post. Rear max mass | 1100 | |
| Massa minima imposta Min. running order mass | 915 | |
| % min. massa OdM su asse posteriore rear axle running order mass min % | 42% | |

Units in mm

| | | | |
|---|--------------|------------------------------|--|
| 1 | 16/11/2015 | pd | Inserito foglio 1 per varianti/versioni GPL - sheet 1 for LPG variants/versions |
| Car Per | Desc Desc | Prov Sig | Descrizione della modifica Modification description |
| Car Data | 20/03/2015 | Caratterizzate Partitions | Indicazioni di carrozzabilità Indication of dimensions for bodywork installation |
|  | | | Design Desc: AEROSOFT VPM Approved:  A.D. COCCO - ART. 14/15/16/17 619637_1  |
| Il presente disegno è proprietà della Piaggio & C. SpA. Riprodurre o usare permesso scritto della stessa nel caso di nuove costruzioni è fatto a discrezione della società proprietaria. Tutti i diritti sono riservati. All proprietary rights reserved by Piaggio & C. SpA. Permission to draw must not be reproduced nor released to other parties without written consent. The Company assumes the rights according to the law. | | | |

Porter Chassis - Greenpower (Methaan)

N1 Homologation Class

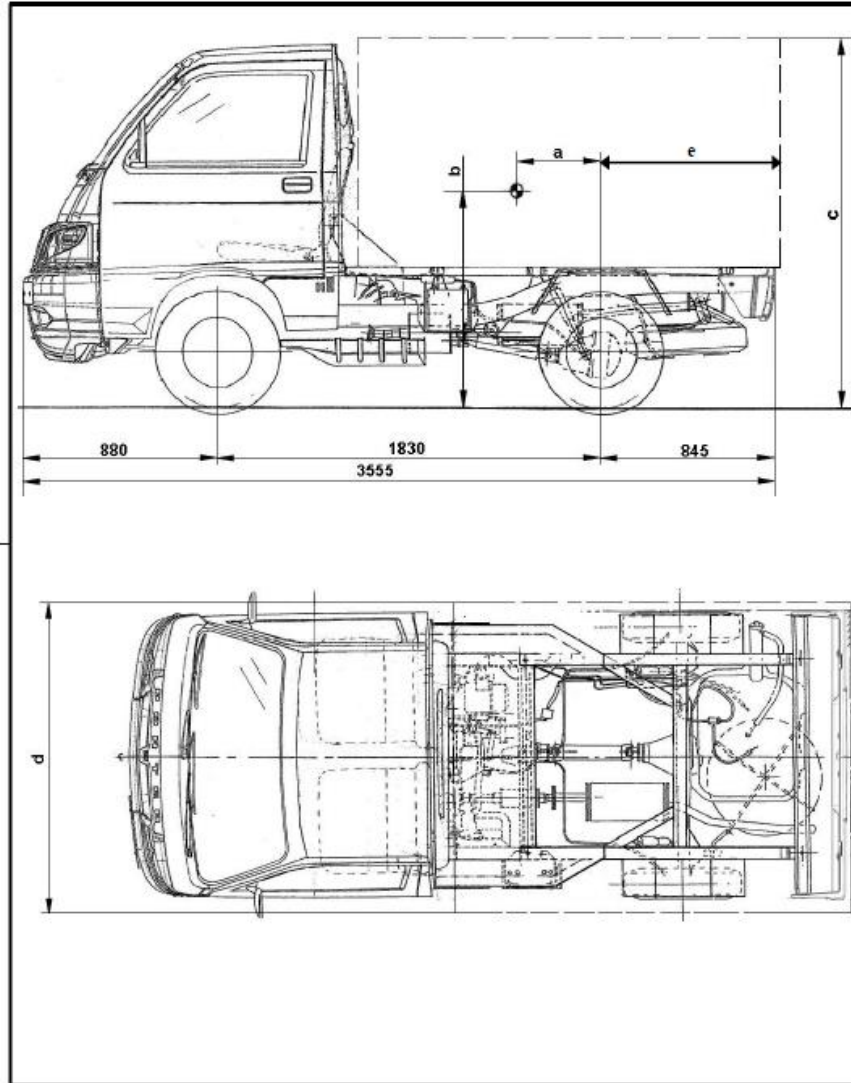

| VAR/VER: CG? / ??N (bi-fuel CNG) | | |
|---|------|------|
| | MIN | MAX |
| a | 51 | 355 |
| b | 600 | 750 |
| d | | 1500 |
| e | 845 | 1065 |
| Massa max ant. Front max mass | 715 | |
| Massa max post. Rear max mass | 1100 | |
| Massa minima imposta Min. running order mass | 980 | |
| % min. massa OdM su asse posteriore rear axle running order mass min % | 42% | |

Units in mm

| | | | | |
|--------------|--------------|--|---|--|
| 2 | 02/05/2016 | pd | foglio 2 per versioni CNG - sheet 2 for CNG versions | |
| 1 | 16/11/2015 | pd | Inserito foglio 1 per varianti/versioni GPL - sheet 1 for LPG variants/versioni | |
| Edi Rev | Data Date | Firma Sign | Descrizione della modifica Modification description | |
| Data Date | 20/03/2015 | Denominazione Part Name | Indicazioni di carrozzabilità | Disegnato Drawn AEROSOFT |
| | | Indication of dimensions for bodywork installation | | Verificato Approved |
| | | <small>Il presente disegno è proprietà della Piaggio & C. SpA. Non è consentito senza permesso scritto dalla stessa non potrà essere comunicato a terzi e o ristampato. La società proprietaria tutela i propri diritti in termini di legge. All proprietary rights reserved by Piaggio & C. SpA. Permission is not to be reproduced nor released to other parties without written consent. The Company asserts one's rights according to the law.</small> | | INDICAZIONE PART NUMBER 619637-2 |

Porter Maxxi Chassis - Multitech

N1 Homologation Class

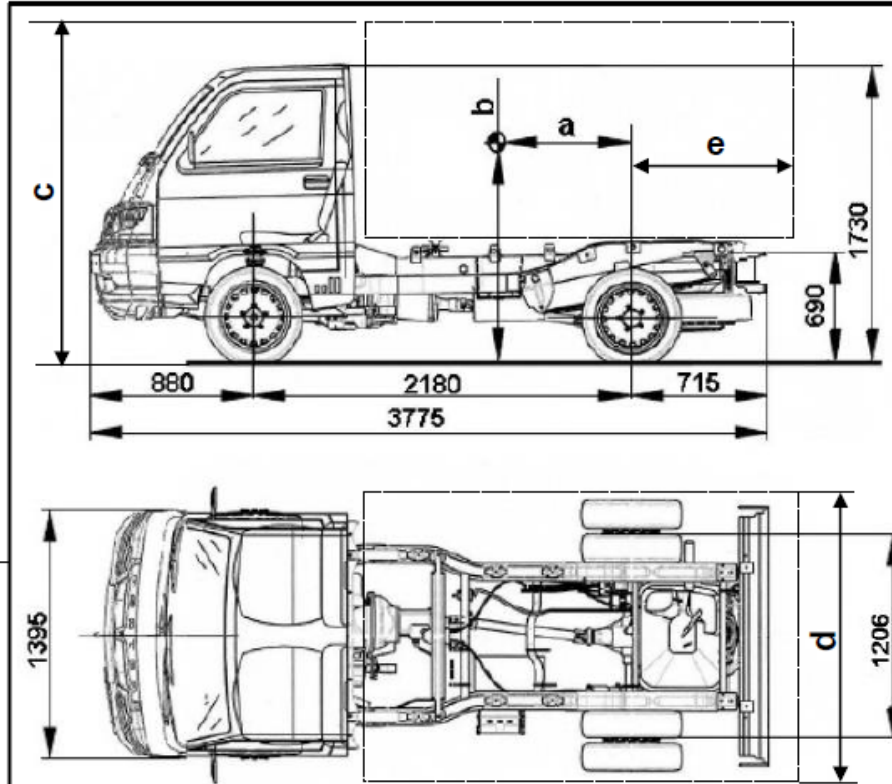

Porter Maxxi

| | MIN | MAX |
|---|------|------|
| a | 140 | 432 |
| b | 617 | 990 |
| d | | 1560 |
| e | 715 | 1300 |
| Massa max ant. Front max mass | 850 | |
| Massa max post. Rear max mass | 1550 | |
| Massa minima imposta Min. running order mass | 1080 | |
| % min. massa OdM su asse posteriore rear axle running order mass min % | 43% | |

Units in mm

| | | | | |
|-----------|------------|-------|--|---|
| 2 | 24/03/2016 | pd | foglio 2 per versioni CNG - sheet 2 for CNG versions ; variata « a » - changes on « a » | |
| 1 | 16/11/2015 | pd | Inserito foglio 1 per varianti/versioni GPL - sheet 1 for LPG variants/versions | |
| Exp. Rev. | Date | Firma | Descrizione della modifica Modification description | |
| Date | 20/03/2015 | | Denominazione Part/Name | Disegnato Drawn |
| | | | Indicazioni di carrozzabilità | AEROSOFT |
| | | | Indication of dimensions for bodywork installation | Visto Approved |
| | | | Il presente disegno è proprietà della Piaggio & C SpA. Permessi e senza permesso scritto della stessa non potrà essere comunicato a terzi e o modificato. La società proprietaria tutela i propri diritti e termini di legge. All proprietary rights reserved by Piaggio & C SpA. Permission without written consent of the same shall not be released to other parties without written consent. The Company asserts one's rights according to the law. | |
| | | | | NOME/PART NUMBER 619638 15 Apr 15 |

Porter Maxxi Chassis - Ecopower (GPL)

N1 Homologation Class

| VARVER(s): AG? / ??F - AG? / ??2 (bi-fuel LPG) | | |
|--|------|------|
| | MIN | MAX |
| a | 102 | 405 |
| b | 617 | 990 |
| d | | 1560 |
| e | 715 | 1300 |
| Massa max ant. Front max mass | 850 | |
| Massa max post. Rear max mass | 1550 | |
| Massa minima imposta Min. running order mass | 1130 | |
| % min. massa OdM su asse posteriore rear axle running order mass min % | 43% | |

Units in mm

Porter Maxxi

| | | | | |
|-------------|--------------|---------------|---|-------------------------------|
| 2 | 24/03/2016 | pd | foglio 2 per versioni CNG - sheet 2 for CNG versions - variata « a » - changes on « a » | |
| 1 | 16/11/2015 | pd | Inserito foglio 1 per varianti/versioni GPL - sheet 1 for LPG variants/versions | |
| Edi File | Desc Desc | Firma Sign | Descrizione della macchina Machine description | |
| Rev Date | 20/03/2015 | | Designazione PartName | Indicazioni di carrozzabilità |
| | | | Indication of dimensions for bodywork installation | |
| | | | <small>Il presente disegno è proprietà della Piaggio & C. SpA. È vietata e sanzionata espressamente la ristampa o l'uso non autorizzato senza permesso scritto della Piaggio & C. SpA. Tutti i diritti sono riservati. / This drawing is the property of Piaggio & C. SpA. All rights are reserved. / This drawing shall not be reproduced or released to other parties without written consent. The Company asserts one's rights according to the law.</small> | |
| | | | DESIGNO-PART NUMBER 619638_1 | |

Porter Maxxi Chassis - Greenpower (Methaan)

N1 Homologation Class

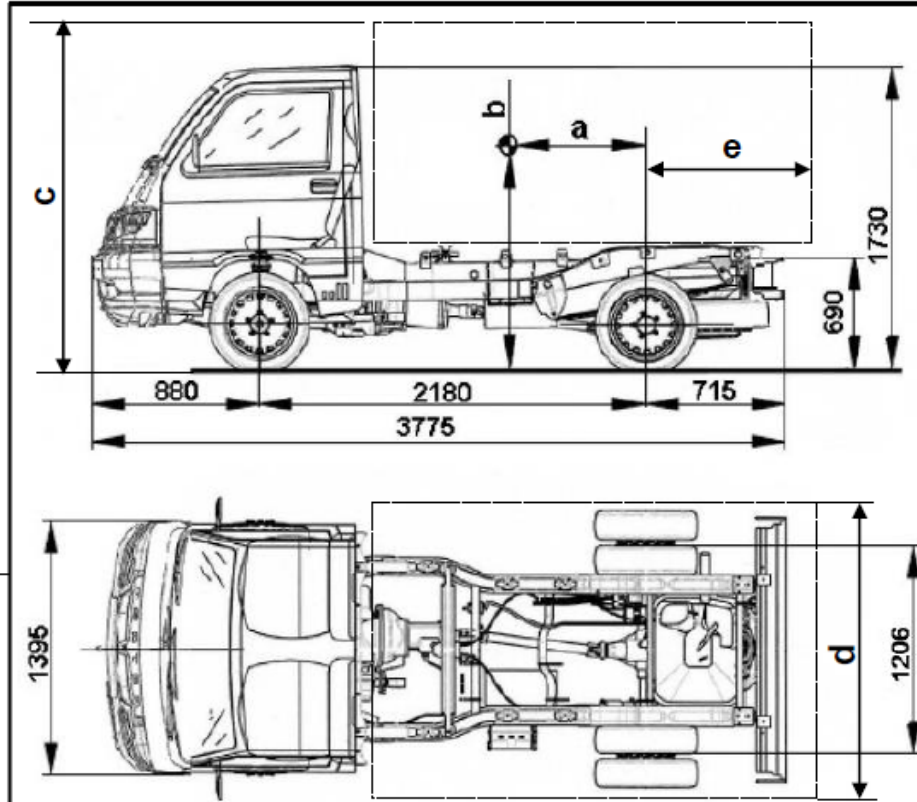

Porter Maxxi

| VAR/VER(s): AG? / ??N | (bi-fuel CNG) | |
|---|---------------|------|
| | MIN | MAX |
| a | 65 | 385 |
| b | 617 | 990 |
| d | | 1560 |
| e | 715 | 1300 |
| Massa max ant. Front max mass | 850 | |
| Massa max post. Rear max mass | 1550 | |
| Massa minima imposta Min. running order mass | 1190 | |
| % min. massa OdM su asse posteriore rear axle running order mass min % | 43% | |

Units in mm

| | | | | |
|--|------------|-------|---|---------------------------------------|
| 2 | 24/03/2016 | pd | foglio 2 per versioni CNG - sheet 2 for CNG versions ; variata « a » - changes on « a » | |
| 1 | 16/11/2015 | pd | Inserito foglio 1 per varianti/versioni GPL - sheet 1 for LPG variants/versions | |
| Exp. Rev. | Date | Sign. | Descrizione della modifica Modification description | |
| 20/03/2015 | | | Denominazione Part/Name | Disegnato Drawn AEROSOFT |
| | | | Indicazioni di carrozzabilità | Verificato Approved |
| | | | Indication of dimensions for bodywork installation | |
| <small>Il presente disegno è proprietà della Piaggio & C SpA. Permessi e senza permesso scritto della stessa non potrà essere comunicato a terzi o riprodotto. La società proprietaria tutela i propri diritti in merito di legge. All proprietary rights reserved by Piaggio & C SpA. Permitted and without written consent of the same shall not be reproduced nor released to other parties without written consent. The Company asserts one's rights according to the law.</small> | | | <small>NUMERO PART NUMBER</small> 619638 2 | <small>20-Apr-15</small> |